



400 Series

404C-22

Compact Industrial and Construction Power

38 kW/51 bhp

Developed in consultation with our marketplace, this 2.2 litre, 4 cylinder engine significantly enhances an already impressive product line-up. It offers all the benefits of the 400 Series range in an ultra-compact, lightweight power unit.

Ultra-compact power

- Up to 38 kW from an engine envelope of 0.20 m³
- Coolant temperature of 110°C allows reduction in radiator size

Clean and quiet

- In addition to its emissions performance, at full load the 404C-22 shows a reduction in smoke levels of 2 Bosch units
- A 3 dBA improvement in bare engine noise is enhanced by a full 5 dBA reduction at low idle
- Noise levels have been kept to a minimum
- Subjective harshness has been carefully controlled making the engine sound even quieter

Durable power

- Product design and process improvements enhance both engine reliability and durability
- A new governor, valve seat inserts, and new compliance testing deliver reliability with 6000 hours durability
- A standard 2 year warranty demonstrates our confidence in durability and reliability

Low operating costs

- Oil and filter changes are now set at 500 hours as standard
- Engine durability and reliability, the warranty offering, and ease of installation combine to drive down the cost of ownership

Product support

- Total worldwide service is provided through 4000 service points around the world



The 400 Series engine family continues to set new standards in the compact engine market. Developed alongside customers to fulfil their needs in the construction, materials handling, agricultural/turf, genset and compressor markets, it has become another class leading diesel range from Perkins.

Built to the most demanding standards, the 400 Series engines meet all the requirements of EC Stage 2 and USA EPA Tier 2 off-highway emissions legislation for 2004, and bring significant improvements over their predecessors.

Long 500 hour service intervals, a two year standard warranty, low noise and harshness, and a wide range of options make the 400 Series range the complete solution for compact power needs.

The 404C-22 is a very quiet 2.2 litre unit delivering improved performance and reduced operating costs in a small, efficient package ideal for a range of off-highway applications.

Performance Data	Gross (ISO/TR 14396)	Speed (rev/min)	Net Intermittent (ISO/TR 14396)	Speed (rev/min)
Power Output (kW)	38.0	3000	35.5	3000
Power Output (bhp)	51.0	3000	47.6	3000
Peak Torque (Nm)	143.0	1800	140.2	1800
Peak Torque (lbf ft)	105.4	1800	103.4	1800

400 Series

404C-22

Engine Specification

- Cast iron engine block
- Flywheel and flywheel housing
- CTD fuel injection pump
- Spin on fuel filter
- Glow plug starting aid
- Lub oil sump
- Spin on lub oil filter
- Inlet manifold
- Cast iron exhaust manifold – side outlet
- Coolant pump belt driven
- Choice of cooling fans
- Starter motor 12 volt
- Alternator 12 volt 65 amp
- ESOS
- Lub oil pressure switch
- Coolant temperature switch
- Provision for PTOs

General Data

Number of cylinders	4 in-line
Bore and stroke	84 x 100 mm
Displacement	2.2 litres
Aspiration	Naturally aspirated
Cycle	4 stroke
Combustion system	Indirect injection
Compression ratio	24.4:1
Rotation	Anti-clockwise viewed on flywheel
Cooling system	Liquid
Total lubrication capacity	10.6 litres
Total coolant capacity	3.6 litres
Dimensions	Length 658 mm Width 425.5 mm Height 725 mm
Dry weight	184 kg

Final weight and dimensions will depend on completed specification.

Option Groups

A selection of optional items is available to enable the customer to prepare a specification precisely matched to their needs.

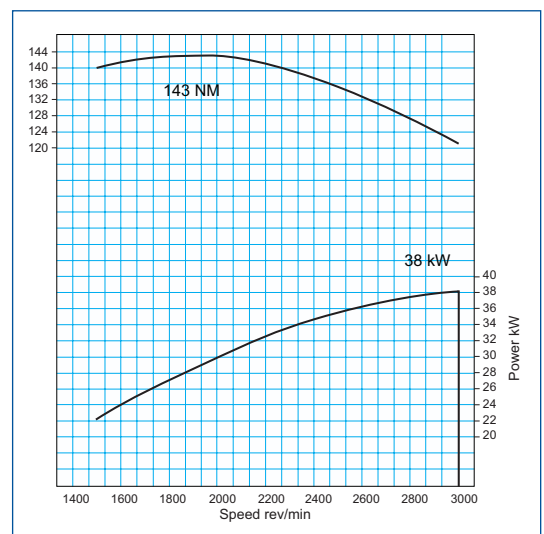
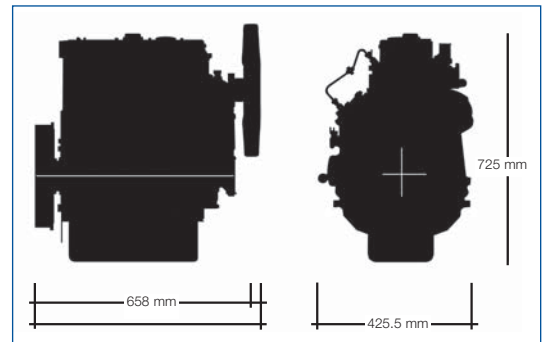

Note: lower speed ratings cannot be read from this curve.



Perkins Engines Company Limited

Peterborough PE1 5NA
United Kingdom
Telephone +44 (0)1733 583000
Fax +44 (0)1733 582240
www.perkins.com

All information in this document is substantially correct at time of printing and may be altered subsequently
Publication No. 1558/10/05 Produced in England ©2005 Perkins Engines Company Limited

Distributed by