



400 Series

404C-15

Compact Agricultural, Lawn and Garden Power

26.5 kW/35.5 bhp

Developed in consultation with the marketplace, this 1.5 litre, 4 cylinder engine greatly enhances the already impressive 400 Series product line-up, offering smooth running power. It is ideally suited to compact Agricultural, Lawn and Garden equipment.



Ultra-compact power

- Up to 26.5 kW from an engine envelope of 0.14 m³
- Easy installation

Clean and quiet

- Noise levels have been kept to a minimum
- Subjective harshness has been carefully controlled making the engine sound even quieter

Durable power

- Product design and process improvements enhance both engine reliability and durability
- A new governor, valve seat inserts, and new compliance testing deliver reliability with 6000 hours durability
- A standard 2 year warranty demonstrates our confidence in durability and reliability

Low operating costs

- Oil and filter changes are now set at 500 hours as standard
- Engine durability and reliability, the warranty offering, and ease of installation combine to drive down the cost of ownership

Product support

- Total worldwide service is provided through 4000 service points around the world

The 400 Series engine family continues to set new standards in the compact engine market. Developed alongside customers to fulfil their needs in the construction, materials handling, agricultural/turf, genset and compressor markets, it has become another class leading diesel range from Perkins.

Built to the most demanding standards, the 400 Series engines meet all the requirements of EC Stage 2 and USA EPA Tier 2 off-highway emissions legislation for 2004, and bring significant improvements over their predecessors.

Long 500 hour service intervals, a two year standard warranty, low noise and harshness, and a wide range of options make the 400 Series range the complete solution for compact power needs.

The 404C-15 is an all new 4 cylinder 1.5 litre unit delivering smooth, impressive performance, with low operating costs in a small, efficient package ideal for the agricultural, lawn and garden sectors.

Performance Data	Gross Power	Speed (rev/min)
Power Output (kW)	24.6	2800
Power Output (bhp)	33.0	2800
Power Output (kW)	26.5	3000
Power Output (bhp)	35.5	3000
Peak Torque (Nm)	96.0	1700
Peak Torque (lb ft)	70.8	1700

400 Series

404C-15

Engine Specification

- Cast iron engine block
- Flywheel and flywheel housing
- Fuel injection pump
- Spin on fuel filter
- Glow plug starting aid
- Lub oil sump
- Spin on lub oil filter
- Inlet manifold
- Cast iron exhaust manifold – side outlet
- Coolant pump belt driven
- Starter motor 12 volt
- Alternator 12 volt 40 amp
- ESOS
- Lub oil pressure switch
- Coolant temperature switch
- Choice of cooling fans
- Provision for PTO (43 Nm continuous; 51 Nm intermittent)
- Cold start capability to -20°C
- Gradeability 35° continuous

General Data

Number of cylinders	4 in-line
Bore and stroke	77 x 81 mm
Displacement	1.5 litres
Aspiration	Naturally aspirated
Cycle	4 stroke
Combustion system	Indirect injection
Compression ratio	23:5:1
Rotation	Anti-clockwise viewed on flywheel
Cooling system	Liquid
Total lubrication capacity	6.0 litres
Total coolant capacity	2.4 litres
Dimensions	Length 591 mm Width 393 mm Height 576 mm
Dry weight	106.8 kg

Final weight and dimensions will depend on completed specification.

Option Groups

A selection of optional items are available to enable customers to prepare a specification precisely matched to their needs.

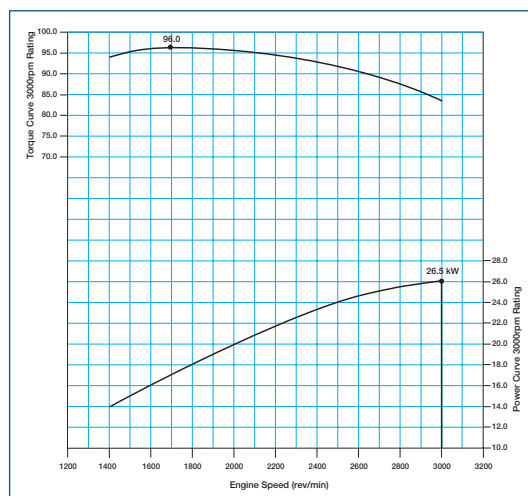
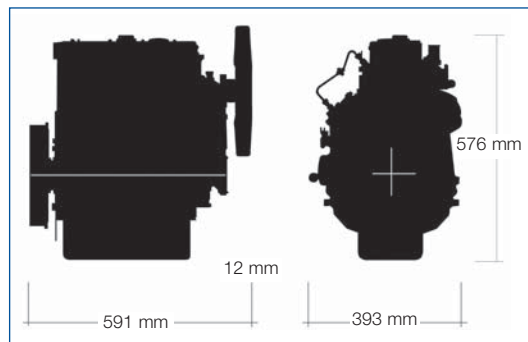

Note: lower speed ratings cannot be read from this curve.



Perkins Engines Company Limited

Peterborough PE1 5NA
United Kingdom
Telephone +44 (0)1733 583000
Fax +44 (0)1733 582240
www.perkins.com

All information in this document is substantially correct at time of printing and may be altered subsequently
Publication No. 1743/10/05 Produced in England ©2005 Perkins Engines Company Limited

Distributed by