



400 Series

403C-15

Industrial Open Power Unit

24.2 kW/32.5 bhp



Outstanding performance

- 25.1 kW (33.7 bhp) performance from a compact complete radiator cooled unit
- Torque backup has risen to over 20%, providing excellent responsiveness when load is increased
- Durability and reliability have been enhanced through product design and process improvements
- A new governor, valve seat inserts and new compliance testing deliver reliability and 6000 hours durability
- Standard two year warranty demonstrates our confidence in the engine

Clean and quiet

- Full-load smoke emissions levels are invisible to the naked eye, measuring less than 2 Bosch
- Noise levels have been kept to a minimum. Subjective harshness has also been controlled, making the engine sound even quieter

Compact fit

- The open power unit benefits from a compact engine design combined with a newly designed more compact radiator package
- The air filter position has also been lowered to further improve compactness

Low operating costs

- Oil and filter changes are now set at 500 hours as standard
- Engine durability and reliability, the warranty offering, and ease of installation combine to drive down the cost of ownership

Product support

- Total worldwide service is provided through 4000 service points around the world

The 400 Series compact engine family has been developed alongside customers to fulfil their needs in the construction, materials handling, agricultural/turf, genset and compressor markets, becoming the latest class-leading diesel range from Perkins.

Built to the most demanding standards, the 400 Series engines meet all the requirements of EC Stage 2 and USA EPA Tier 2 off-highway emissions legislation and bring significant improvements over their predecessors.

Perkins IOPUs offer the advantages of an industrial engine, with the convenience of a cost effective cooling and filtration solution. This minimises machine development time and costs, and enables applications to be powered with ease.

The 403C-15 IOPU is a powerful but quiet 1.5 litre packaged unit. It delivers impressive performance with low operating costs in a small, efficient package ideal for a range of industrial applications.

Performance Data	Net Intermittent (ISO/TR 14396)	Speed (rev/min)
Power Output (kW)	24.2	3000
Power Output (bhp)	32.5	3000
Peak Torque (Nm)	128.0	1800
Peak Torque (lbf ft)	94.4	1800

Power output for a run-in engine after 60 hours.

Photographs are for illustrative purposes only and may not reflect final specification.

400 Series

403C-15

Engine Specification

- Cast iron engine block
- SAE Flywheel size 6½
- SAE 5 flywheel housing
- Fuel injection pump
- Fuel filter
- Glow plug starting aid
- Lub oil sump
- Spin on lub oil filter
- Inlet manifold
- Cast iron exhaust manifold – side outlet
- Coolant pump belt driven
- Mounted radiator and fan
- Mounted air cleaner
- Starter motor 12 volt
- Alternator 12 volt 65 amp
- ESOS
- Lub oil pressure switch
- Coolant temperature switch

General Data

Number of cylinders	3 in-line
Bore and stroke	84 x 90 mm
Displacement	1.5 litres
Aspiration	Naturally aspirated
Cycle	4 stroke
Combustion system	Indirect injection
Compression ratio	22.5:1
Rotation	Anti-clockwise viewed on flywheel
Cooling system	Pressurised water
Total lubrication capacity	6 litres
Total coolant capacity	5.98 litres
Dimensions	Length 820 mm Width 476 mm Height 791 mm
Dry weight	175 kg

Final weight and dimensions will depend on completed specification.

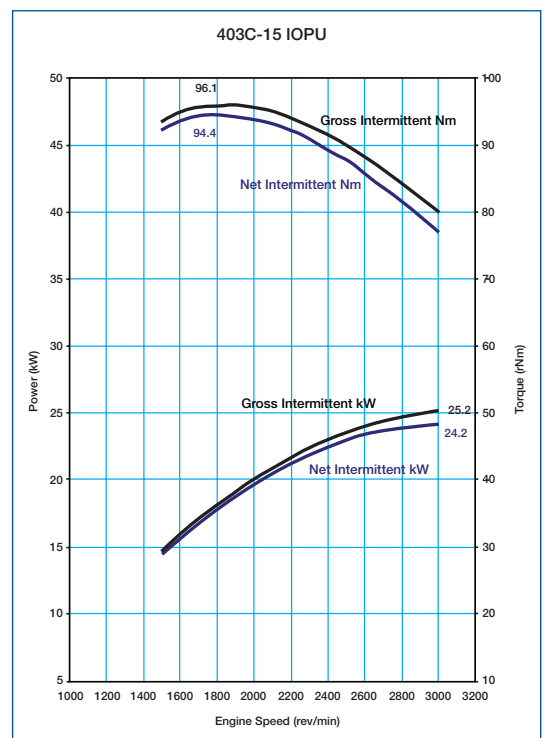
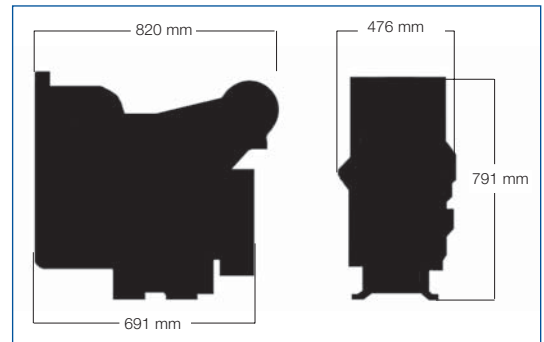

Lower speed ratings cannot be read from this curve.

Option Groups

A selection of optional items is available to enable the customer to prepare a specification precisely matched to their needs.



Perkins Engines Company Limited

Peterborough PE1 5NA
United Kingdom
Telephone +44 (0)1733 583000
Fax +44 (0)1733 582240
www.perkins.com

All information in this document is substantially correct at time of printing and may be altered subsequently
Publication No. 1777/10/05 Produced in England ©2005 Perkins Engines Company Limited

Distributed by